

Versal AI Edge VE2302 SOM User Manual

V100

REV Version 1.0

ALINX ELECTRONIC LIMITED

WWW.EN.ALINX.COM

Version Record

Version	Date	Release By	Description
Rev 1.0	2024/2/29	Kathy Xia	First Release

Table of Contents

Version Record	2
Part 1: VE2302 SOM	4
Part 1.1: Introduction	4
Part 1.2: VE2302	5
Part 1.3: Clock Configuration.....	6
Part 1.4: DDR4 DRAM.....	7
Part 1.5: QSPI Flash	11
Part 1.6: eMMC Flash	12
Part 1.7: LEDs	13
Part 1.8: Power Supply.....	13
Part 1.9: Expansion Interface	14
Part 1.10: Structure Diagram	20

Part 1: VE2302 SOM

Part 1.1: Introduction

V100 (SOM model, the same below) SOM is a high-performance module developed based on XCVE2302-SFVA784-1LP-E-S chip of Versal ACAP series of XILINX. It has the characteristics of high performance, low latency, edge computing and low power consumption, and is suitable for data center, video image processing and high-speed data processing, etc.

This module uses four MT40A512M16LY-062E chips of MICRON. The DDR4 chip has 64-bit data bus bandwidth and 4GB capacity; DDR4 SDRAM can run at a maximum speed of 1600MHz (data rate of 3200Mbps). In addition, two 256MBit QSPI FLASH chips and one 8GB EMMC chip are integrated on the module for boot storage configuration and system files.

The PS side of this module expands 53 MIOs of 1.8 V level standard, the PL side expands 22 standard IOs of 3.3 V level, 54 standard IO ports of 1.8 V level, 30 standard IOs of 1.2 V level and 8 pairs of GTY high-speed RX/TX differential signals. Moreover, the wiring between the FPGA chip and the interface is processed with equal length and difference, and the size of the module is only 65 * 60 (mm), which is very suitable for secondary development.



Figure 1: Front view of V100 module

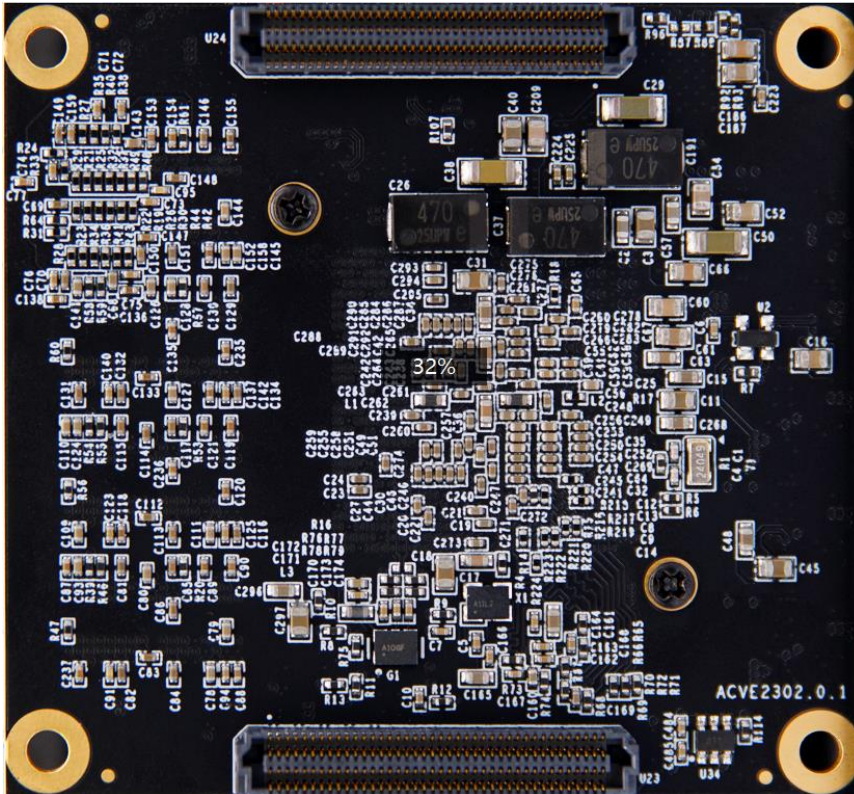
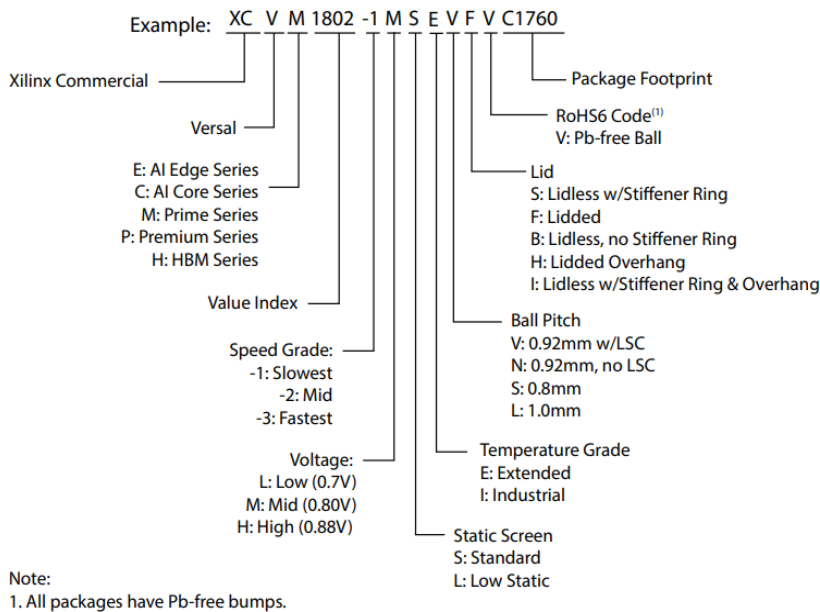

Figure 2: Back view of V100 module

Part 1.2: VE2302

As mentioned earlier, the Versal ACAP model we use is XCVE2302-SFVA784-1LP-E-S, speed class 1, operating temperature 0~100°C, and package SFVA784. The chip naming convention for Versal ACAP is as follows:



DS950_03_101922

Figure 3: Versal Ordering Information

The VE2302 chip integrates four ARM Cortex™ -A72 processors and two Cortex-R5F processors, as well as 34 AI Engines-ML acceleration units and 464 DSP processing units. The internal resources of the VE2302 are as follows:

	VE2002	VE2102	VE2202	VE2302	VE1752	VE2602	VE2802
AI Engines-ML	8	12	24	34	0	152	304
AI Engines	0	0	0	0	304	0	0
AIE/AIE-ML Data Memory (Mb)	4	6	12	17	76	76	152
AIE-ML Shared Memory (Mb)	48	48	68	68	0	304	304
AIE to NoC Interface Tiles	2	2	6	6	12	12	12
AIE to PL Interface Tiles	7	7	12	12	27	28	28
DSP Engines	90	176	324	464	1,312	984	1,312
System Logic Cells	43,750	80,080	229,688	328,720	981,120	820,313	1,139,040
CLB Flip-Flops	40,000	73,216	210,000	300,544	897,024	750,000	1,041,408
LUTs	20,000	36,608	105,000	150,272	448,512	375,000	520,704
Distributed RAM (Mb)	0.6	1.1	3.2	4.6	13.7	11.4	15.9
Block RAM Blocks	24	47	108	155	954	476	600
Block RAM (Mb)	0.8	1.7	3.8	5.4	33.5	16.7	21.1
UltraRAM Blocks	24	47	108	155	462	224	264
UltraRAM (Mb)	6.8	13.2	30.4	43.6	129.9	63.0	74.3
Accelerator RAM (Mb)	32	32	32	32	0	0	0
APU	Dual-core Arm® Cortex-A72, 48KB/32KB L1 Cache w/ parity & ECC; 1MB L2 Cache w/ ECC						
RPU	Dual-core Arm Cortex-R5F, 32KB/32KB L1 Cache, and 256KB TCM w/ECC						
Memory	256KB On-Chip Memory w/ECC						
Connectivity	Ethernet (x2); UART (x2); CAN-FD (x2); USB 2.0 (x1); SPI (x2); I2C (x2)						
NoC to PL Master/ Slave Ports	2	2	5	5	21	21	21
DDR Bus Width	64	64	64	64	192	192	192
DDR Memory Controllers (DDRM/C)	1	1	1	1	3	3	3
PCIe w/DMA & CCIX (CPM4)	-	-	-	-	1 x Gen4x16, CCIX	-	-
PCIe w/DMA & CCIX (CPM5)	-	-	-	-	-	1 x Gen4x16, CCIX	1 x Gen4x16, CCIX
PCIe (PLPCIe4)	-	-	1 x Gen4x8	1 x Gen4x8	4 x Gen4x8	-	-
PCIe (PLPCIe5)	-	-	-	-	-	4 x Gen4x8	4 x Gen4x8
40G Multirate Ethernet MAC	0	0	1	1	2	2	2
XPIO	216	216	216	216	486	486	486
HDIO	0	0	22	22	44	44	44
GTY Transceivers ⁽¹⁾	0	0	0	0	44	0	0
GTP Transceivers ⁽¹⁾	0	0	8	8	0	32 ⁽²⁾	32 ⁽²⁾
Video Decoder Engines (VDEs)	-	-	-	-	-	2	4

Figure 4: Internal Resources of VE2302

Part 1.3: Clock Configuration

The V100 module provides a reference clock and an RTC real-time clock for the PS system and the PL logic respectively, so that the PS system and the PL logic can work independently. The schematic diagram of the clock circuit design is shown in Figure 5 below:

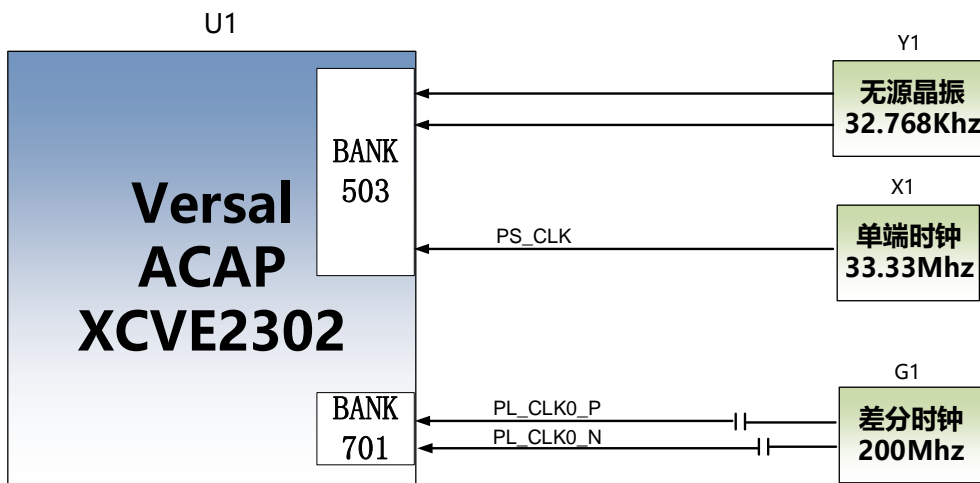

Figure 5: SOM Clock Source

- **PS system RTC real-time clock**

The passive crystal Y1 on the module provides a 32.768KHz real-time clock source for the PS system. The crystal is connected to the pins of RTC _ PADI _ 503 and RTC _ PADO _ 503 of bank 503 of the VE2302 chip.

- **PS system clock source**

The X1 crystal on the module provides a 33.333MHz clock input to the PS system. The input of the clock is connected to the pin PS _ REF _ CLK _ 503 of BANK503 of the VE2302 chip.

- **PL system clock source**

A differential 200MHz PL system clock source is provided on module for the reference clock of the DDR4 controller. The crystal output is connected to the global clock (GC) of PL BANK701, which can be used to drive the DDR4 controller and user logic circuits in the FPGA.

PL clock pin assignment

Signal name	VE2302 pin name	VE2302 pin number
PL_CLK0_N	IO_L24N_GC_XCC_N8P1_M0P103_701	AC23
PL_CLK0_P	IO_L24P_GC_XCC_N8P0_M0P102_701	AB23

Table 1: PL Clock pin Assignment

Part 1.4: DDR4 DRAM

The V100 module is equipped with four Micron 1GB DDR4 chips, model MT40A512M16LY-062E. Four DDR4 chips are hung on the XPIO of BANK700, 701 and 702, forming a 64-bit data bus bandwidth and a capacity of 4GB. DDR4 SDRAM can run up to 1600MHz (3200Mbps data rate). The specific configuration of DDR4 SDRAM is shown in Table 2 below.

Tag number	Chip model	Capacity	Manufacturer
U5, U8, U9, U10	MT40A512M16LY-062E	512M x 16bit	Micron

Table 2: DDR4 SDRAM Configuration

The hardware design of DDR4 needs to strictly consider the signal integrity. We have fully considered the matching resistor/terminal resistor, trace impedance control, and trace equal length control during circuit design and PCB design to ensure the high-speed and stable operation of DDR4. The hardware connection mode of DDR4 is shown in Figure 6:

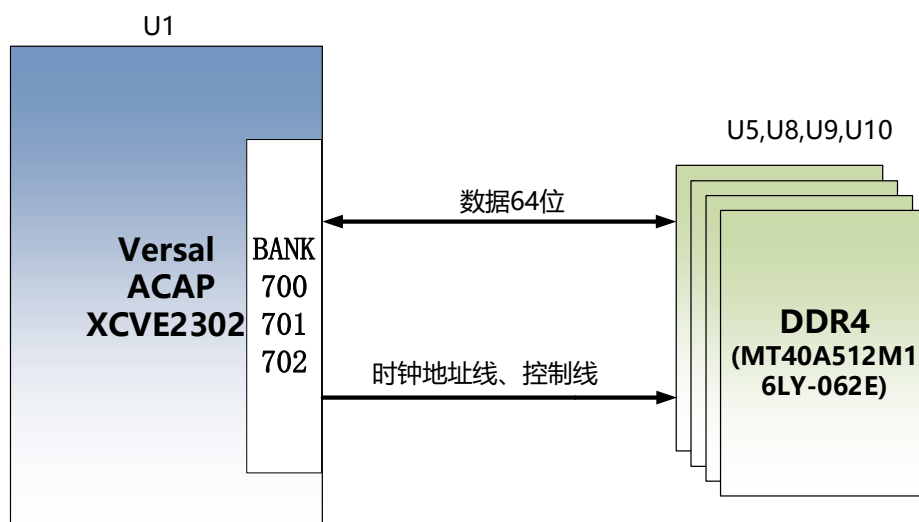

Figure 6: DDR4 DRAM Schematic

DDR4 SDRAM pin assignment

Signal name	Pin name	Pin number
PL_DDR4_A0	IO_L18P_XCC_N6P0_M0P36_700	AB12
PL_DDR4_A1	IO_L17N_N5P5_M0P35_700	AE22
PL_DDR4_A2	IO_L17P_N5P4_M0P34_700	AD22
PL_DDR4_A3	IO_L20P_N6P4_M0P40_700	AB15
PL_DDR4_A4	IO_L12P_GC_XCC_N4P0_M0P24_700	AD12
PL_DDR4_A5	IO_L26P_N8P4_M0P52_700	AE17
PL_DDR4_A6	IO_L24P_GC_XCC_N8P0_M0P48_700	AD16
PL_DDR4_A7	IO_L6N_GC_XCC_N2P1_M0P13_700	AG11
PL_DDR4_A8	IO_L25N_N8P3_M0P51_700	AE14
PL_DDR4_A9	IO_L19P_N6P2_M0P38_700	AB14
PL_DDR4_A10	IO_L21N_XCC_N7P1_M0P43_700	AB17
PL_DDR4_A11	IO_L25P_N8P2_M0P50_700	AE13
PL_DDR4_A12	IO_L0N_XCC_N0P1_M0P1_700	AH12
PL_DDR4_A13	IO_L24N_GC_XCC_N8P1_M0P49_700	AD15
PL_DDR4_CLK_N	IO_L15N_XCC_N5P1_M0P31_700	AD19
PL_DDR4_CLK_P	IO_L15P_XCC_N5P0_M0P30_700	AC19
PL_DDR4_BA0	IO_L20N_N6P5_M0P41_700	AC16
PL_DDR4_BA1	IO_L12N_GC_XCC_N4P1_M0P25_700	AD11
PL_DDR4_WE_B	IO_L16N_N5P3_M0P33_700	AD21
PL_DDR4_CAS_B	IO_L14N_N4P5_M0P29_700	AD17
PL_DDR4_CS_B	IO_L14P_N4P4_M0P28_700	AC17
PL_DDR4_ACT_B	IO_L18N_XCC_N6P1_M0P37_700	AC11
PL_DDR4_RAS_B	IO_L19N_N6P3_M0P39_700	AC13
PL_DDR4_BG0	IO_L21P_XCC_N7P0_M0P42_700	AB18
PL_DDR4_ODT	IO_L23N_N7P5_M0P47_700	AC22

PL_DDR4_CKE	IO_L23P_N7P4_M0P46_700	AB21
PL_DDR4_RST	IO_L25P_N8P2_M0P104_701	AC24
PL_DDR4_DQS0_N	IO_L9N_GC_XCC_N3P1_M0P19_700	AG16
PL_DDR4_DQS0_P	IO_L9P_GC_XCC_N3P0_M0P18_700	AG17
PL_DDR4_DQS1_N	IO_L3N_XCC_N1P1_M0P7_700	AH19
PL_DDR4_DQS1_P	IO_L3P_XCC_N1P0_M0P6_700	AG20
PL_DDR4_DQS2_N	IO_L6N_GC_XCC_N2P1_M0P67_701	AD27
PL_DDR4_DQS2_P	IO_L6P_GC_XCC_N2P0_M0P66_701	AC28
PL_DDR4_DQS3_N	IO_L3N_XCC_N1P1_M0P61_701	AF23
PL_DDR4_DQS3_P	IO_L3P_XCC_N1P0_M0P60_701	AF24
PL_DDR4_DQS4_N	IO_L15N_XCC_N5P1_M0P85_701	AA23
PL_DDR4_DQS4_P	IO_L15P_XCC_N5P0_M0P84_701	Y24
PL_DDR4_DQS5_N	IO_L21N_XCC_N7P1_M0P97_701	Y27
PL_DDR4_DQS5_P	IO_L21P_XCC_N7P0_M0P96_701	Y28
PL_DDR4_DQS6_N	IO_L0N_XCC_N0P1_M0P109_702	U28
PL_DDR4_DQS6_P	IO_L0P_XCC_N0P0_M0P108_702	U27
PL_DDR4_DQS7_N	IO_L9N_GC_XCC_N3P1_M0P127_702	N27
PL_DDR4_DQS7_P	IO_L9P_GC_XCC_N3P0_M0P126_702	P26
PL_DDR4_DM0	IO_L6P_GC_XCC_N2P0_M0P12_700	AG12
PL_DDR4_DM1	IO_L0P_XCC_N0P0_M0P0_700	AH13
PL_DDR4_DM2	IO_L9P_GC_XCC_N3P0_M0P72_701	AE28
PL_DDR4_DM3	IO_L0P_XCC_N0P0_M0P54_701	AD24
PL_DDR4_DM4	IO_L12P_GC_XCC_N4P0_M0P78_701	V22
PL_DDR4_DM5	IO_L18P_XCC_N6P0_M0P90_701	V28
PL_DDR4_DM6	IO_L3P_XCC_N1P0_M0P114_702	N28
PL_DDR4_DM7	IO_L6P_GC_XCC_N2P0_M0P120_702	U25
PL_DDR4_DQ0	IO_L8P_N2P4_M0P16_700	AF14
PL_DDR4_DQ1	IO_L10N_N3P3_M0P21_700	AG18
PL_DDR4_DQ2	IO_L8N_N2P5_M0P17_700	AG15
PL_DDR4_DQ3	IO_L10P_N3P2_M0P20_700	AF18
PL_DDR4_DQ4	IO_L7P_N2P2_M0P14_700	AF13
PL_DDR4_DQ5	IO_L11N_N3P5_M0P23_700	AF19
PL_DDR4_DQ6	IO_L7N_N2P3_M0P15_700	AG13
PL_DDR4_DQ7	IO_L11P_N3P4_M0P22_700	AE19
PL_DDR4_DQ8	IO_L2P_N0P4_M0P4_700	AH17
PL_DDR4_DQ9	IO_L4P_N1P2_M0P8_700	AG21
PL_DDR4_DQ10	IO_L2N_N0P5_M0P5_700	AH18
PL_DDR4_DQ11	IO_L4N_N1P3_M0P9_700	AH20
PL_DDR4_DQ12	IO_L1P_N0P2_M0P2_700	AH14
PL_DDR4_DQ13	IO_L5N_N1P5_M0P11_700	AH22
PL_DDR4_DQ14	IO_L1N_N0P3_M0P3_700	AH15
PL_DDR4_DQ15	IO_L5P_N1P4_M0P10_700	AG22

PL_DDR4_DQ16	IO_L8N_N2P5_M0P71_701	AF26
PL_DDR4_DQ17	IO_L7N_N2P3_M0P69_701	AE26
PL_DDR4_DQ18	IO_L10N_N3P3_M0P75_701	AH27
PL_DDR4_DQ19	IO_L8P_N2P4_M0P70_701	AE27
PL_DDR4_DQ20	IO_L11N_N3P5_M0P77_701	AG27
PL_DDR4_DQ21	IO_L7P_N2P2_M0P68_701	AD26
PL_DDR4_DQ22	IO_L11P_N3P4_M0P76_701	AG26
PL_DDR4_DQ23	IO_L10P_N3P2_M0P74_701	AG28
PL_DDR4_DQ24	IO_L1N_N0P3_M0P57_701	AE24
PL_DDR4_DQ25	IO_L1P_N0P2_M0P56_701	AD25
PL_DDR4_DQ26	IO_L5P_N1P4_M0P64_701	AH24
PL_DDR4_DQ27	IO_L2P_N0P4_M0P58_701	AF25
PL_DDR4_DQ28	IO_L4P_N1P2_M0P62_701	AG23
PL_DDR4_DQ29	IO_L2N_N0P5_M0P59_701	AG25
PL_DDR4_DQ30	IO_L4N_N1P3_M0P63_701	AH23
PL_DDR4_DQ31	IO_L5N_N1P5_M0P65_701	AH25
PL_DDR4_DQ32	IO_L17P_N5P4_M0P88_701	Y22
PL_DDR4_DQ33	IO_L13P_N4P2_M0P80_701	V23
PL_DDR4_DQ34	IO_L16P_N5P2_M0P86_701	Y23
PL_DDR4_DQ35	IO_L13N_N4P3_M0P81_701	W24
PL_DDR4_DQ36	IO_L16N_N5P3_M0P87_701	AA22
PL_DDR4_DQ37	IO_L14P_N4P4_M0P82_701	V24
PL_DDR4_DQ38	IO_L17N_N5P5_M0P89_701	AA21
PL_DDR4_DQ39	IO_L14N_N4P5_M0P83_701	W25
PL_DDR4_DQ40	IO_L19P_N6P2_M0P92_701	V25
PL_DDR4_DQ41	IO_L20P_N6P4_M0P94_701	W27
PL_DDR4_DQ42	IO_L22P_N7P2_M0P98_701	AA28
PL_DDR4_DQ43	IO_L19N_N6P3_M0P93_701	W26
PL_DDR4_DQ44	IO_L20N_N6P5_M0P95_701	Y26
PL_DDR4_DQ45	IO_L23P_N7P4_M0P100_701	AA26
PL_DDR4_DQ46	IO_L22N_N7P3_M0P99_701	AB28
PL_DDR4_DQ47	IO_L23N_N7P5_M0P101_701	AB26
PL_DDR4_DQ48	IO_L2P_N0P4_M0P112_702	P27
PL_DDR4_DQ49	IO_L5P_N1P4_M0P118_702	K27
PL_DDR4_DQ50	IO_L2N_N0P5_M0P113_702	R28
PL_DDR4_DQ51	IO_L4N_N1P3_M0P117_702	L28
PL_DDR4_DQ52	IO_L1P_N0P2_M0P110_702	R27
PL_DDR4_DQ53	IO_L5N_N1P5_M0P119_702	K28
PL_DDR4_DQ54	IO_L1N_N0P3_M0P111_702	T28
PL_DDR4_DQ55	IO_L4P_N1P2_M0P116_702	M27
PL_DDR4_DQ56	IO_L8P_N2P4_M0P124_702	P25
PL_DDR4_DQ57	IO_L10N_N3P3_M0P129_702	L26

PL_DDR4_DQ58	IO_L8N_N2P5_M0P125_702	R26
PL_DDR4_DQ59	IO_L10P_N3P2_M0P128_702	M26
PL_DDR4_DQ60	IO_L7P_N2P2_M0P122_702	T25
PL_DDR4_DQ61	IO_L11N_N3P5_M0P131_702	K26
PL_DDR4_DQ62	IO_L7N_N2P3_M0P123_702	T26
PL_DDR4_DQ63	IO_L11P_N3P4_M0P130_702	J25

Table 3: DDR4 SDRAM pin Assignment

Part 1.5: QSPI Flash

The SOM uses two 256Mbit QSPI FLASH chips, model MT25QU256ABA1EW9-0SIT, which uses 1.8 V CMOS voltage standard. Because of its non-volatile nature, QSPI FLASH can be used as a boot image for FPGA systems in use. These images mainly include FPGA bit files, soft-core application code and other user data files.

See the following table 4 for the specific model and relevant parameters of QSPI FLASH.

Tag number	Type of chip	Capacity	Manufacturer
U3, U4	MT25QU256ABA1EW9-0SIT	256M Bit	Micron

Table 4: Model and Parameters of QSPI Flash

QSPI FLASH is connected to the XPIO port of BANK500, the PS part of Versal ACAP chip. In the system design, it is necessary to configure the MIO port function of these PS ends as QSPI FLASH interface.

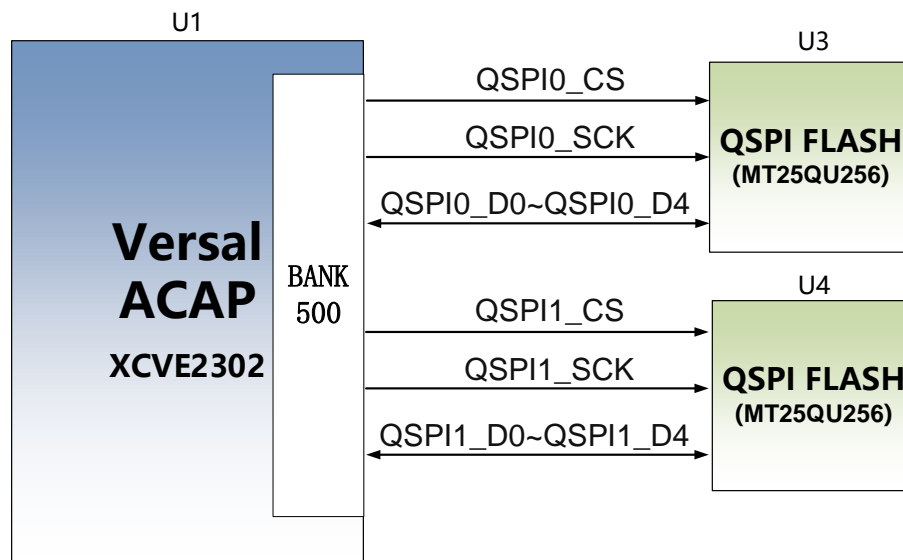

Figure 7: QSPI Flash Connection Diagram

Configure chip pin assignment

Signal name	Pin name	Pin number
MIO0_QSPI0_SCLK	PMC_MIO0_500	AA1
MIO1_QSPI0_IO1	PMC_MIO1_500	AB1

MIO2_QSPI0_IO2	PMC_MIO2_500	AD1
MIO3_QSPI0_IO3	PMC_MIO3_500	AE1
MIO4_QSPI0_IO0	PMC_MIO4_500	AF1
MIO5_QSPI0_SS_B	PMC_MIO5_500	AG1
MIO7_QSPI1_SS_B	PMC_MIO7_500	AG2
MIO8_QSPI1_IO0	PMC_MIO8_500	AE2
MIO9_QSPI1_IO1	PMC_MIO9_500	AD2
MIO10_QSPI1_IO2	PMC_MIO10_500	AC2
MIO11_QSPI1_IO3	PMC_MIO11_500	AB2
MIO12_QSPI1_SCLK	PMC_MIO12_500	AA3

Table 5: Configure Chip pin Assignment

Part 1.6: eMMC Flash

The V100 module is equipped with a large-capacity 8GB eMMC FLASH chip, model MTFC8GAKAJCN-4M, which supports the HS-MMC interface of the JEDEC e-MMC V5.0 standard, and the level supports 1.8 V or 3.3 V. The data width of eMMC FLASH and ACAP connections is 8 bits. Because of its large capacity and non-volatile characteristics, eMMC FLASH can be used as a large-capacity storage device in ACAP system, such as storing ARM applications, system files and other user data files. See Table 6 for the specific model and relevant parameters of eMMC FLASH.

Tag number	Type of chip	Capacity	Manufacturer
U8	MTFC8GAKAJCN-4M	8G Byte	Micron

Table 6: Model and parameters of eMMC Flash

eMMC FLASH is connected to PMC MIO port of BANK501 of PS part of Versal ACAP, and these PMC MIO ports shall be configured as EMMC interfaces in system design. Figure 10 shows the part of eMMC Flash in the schematic diagram.

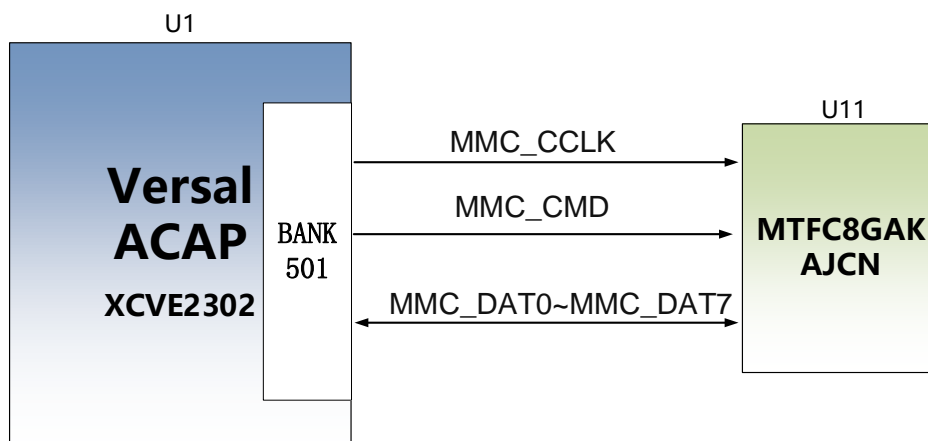

Figure 8: eMMC Flash Connection Diagram

Configure chip pin assignment

Signal name	Pin name	Pin number
MMC_CCLK	PMC_MIO38_501	AE8
MMC_CMD	PMC_MIO40_501	AB8
MMC_DAT0	PMC_MIO41_501	AA8
MMC_DAT1	PMC_MIO42_501	AA9
MMC_DAT2	PMC_MIO43_501	AC9
MMC_DAT3	PMC_MIO44_501	AD9
MMC_DAT4	PMC_MIO45_501	AE9
MMC_DAT5	PMC_MIO46_501	AF9
MMC_DAT6	PMC_MIO47_501	AF10
MMC_DAT7	PMC_MIO48_501	AD10
MMC_RSTN	PMC_MIO49_501	AC10

Table 7: Configure Chip pin Assignment

Part 1.7: LEDs

The V100 module has a red power supply indicator (PWR) and a configuration LED (DONE). The power indicator lights up when the module is powered on, and the configuration LED lights up when the FPGA configuration program is on. Schematic diagram of hardware connection of LED lamp is shown in Figure 9:

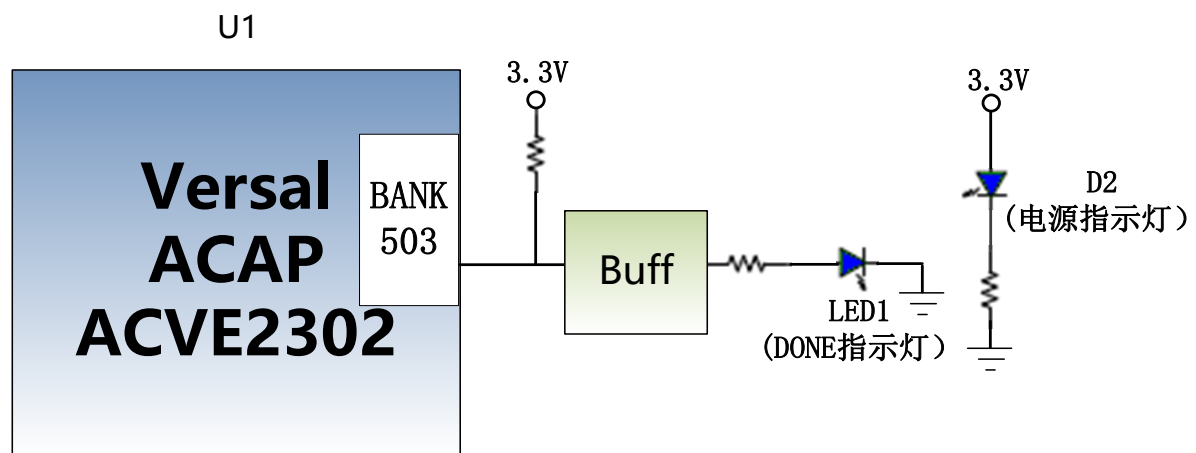

Figure 9: Schematic diagram of hardware connection of led lamp on development board

Part 1.8: Power Supply

The V100 module power supply voltage is 7.5V to 15 V (12 V typical), and the module is powered by connecting the baseboard. The MYMGM1R824ELA5RA power supply chip on the module provides 0.7V core power supply for XCVE2302. In addition, the power supply of BANK503, BANK700 and BANK302 is generated by DCDC chip TLV62130RGT. Power for the BANK703 and GTY transceivers is generated by the LDO chip.

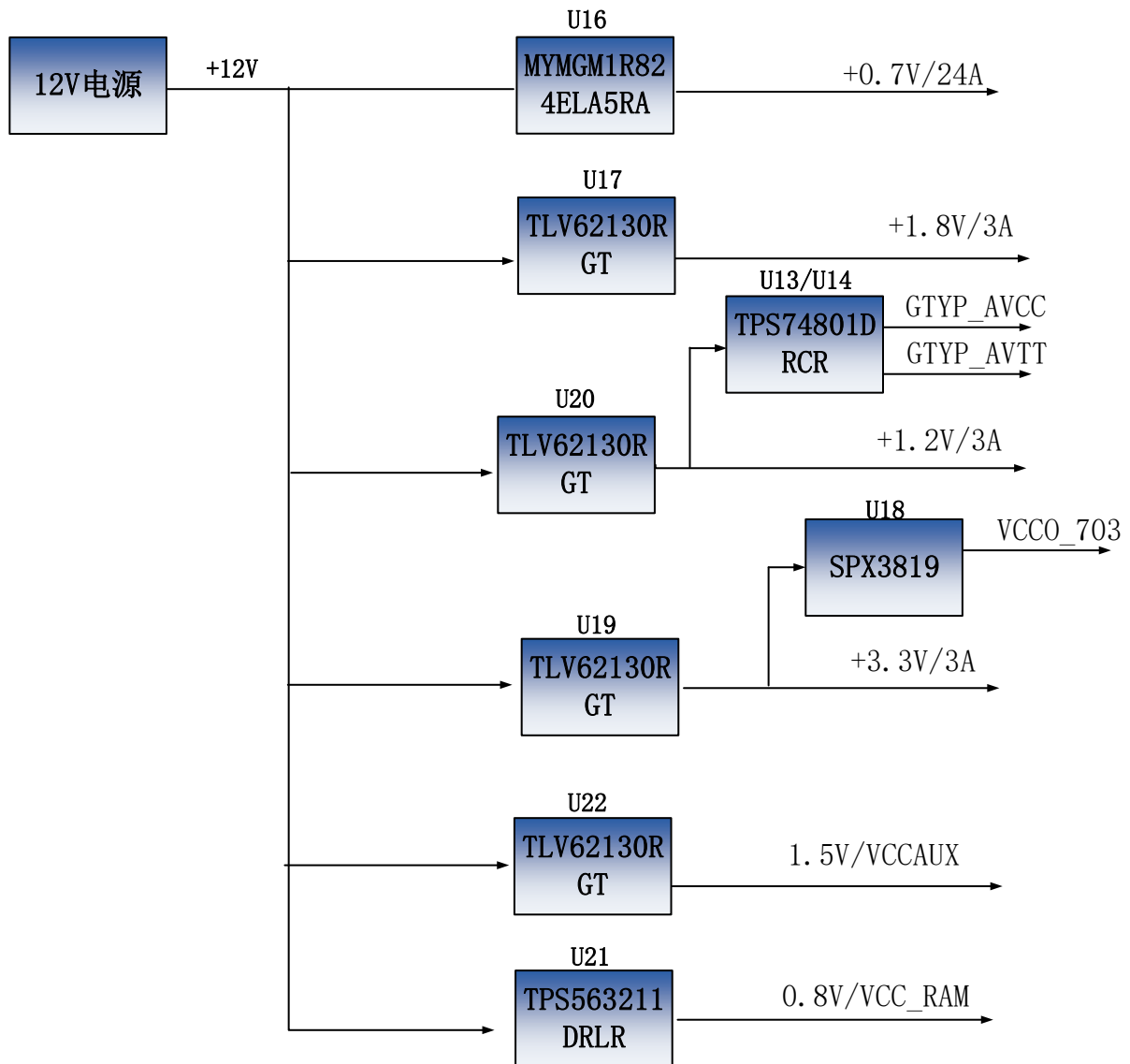

Figure 10: Power Supply

Because the power supply of the Versal ACAP FPGA has a power-on sequence requirement, in the circuit design, we have designed the power-on sequence according to the power supply requirement of the chip as follows:

- VCCIO503(3.3V), VCCO302(3.3V), VCCIO_501/502/503 (1.8V), VCCIO700/701/702(1.2V)
- VCCINT/VCC_PMC/VCC_PSF/P/VCC_PSLP (0.7V)
- VCCBRAM/VCC_SOC/VCC_IO (0.8V)
- VCCBRAM/VCC_SOC/VCC_IO (0.8V)
- GTYP_AVCC (0.9V)
- GTYP_AVTT (1.2V)

Part 1.9: Expansion Interface

A total of two high-speed expansion ports are extended on the back of the module.

Two 160-pin inter-board connectors (Samtec: ADF6-40-03.5-L-4-2-A-TR) are used to connect to the base board. The IO port of the FPGA is connected to these two expansion ports through differential wiring. The

PIN spacing of the connector is 0.5mm, and high-speed data communication is realized with the female connector configuration of the base board.

- **Expansion port U23_AB**

The 160-pin connector U23 is used to connect the VCCIN power supply (+ 12V) of the base board, the ground wire, and the ordinary IO of the FPGA. It should be noted here that the A and B columns of U23 are connected to the IO ports of BANK702 and PS. Pin assignment of U23_AB expansion port is shown in Table 8:

U23 pin	Signal Name	FPGA Pin number	Level standard	U23 Pin	Signal Name	FPGA Pin number	Level standard
A1	B702_L17_N	J24	1.2V	B1	B702_L12_N	T24	1.2V
A2	B702_L17_P	K23	1.2V	B2	B702_L12_P	U23	1.2V
A3	GND	-	Ground	B3	GND	-	Ground
A4	B702_L25_N	L25	1.2V	B4	B702_L16_N	K24	1.2V
A5	B702_L25_P	L24	1.2V	B5	B702_L16_P	L23	1.2V
A6	GND	-	Ground	B6	GND	-	Ground
A7	B702_L24_N	N24	1.2V	B7	B702_L21_N	M21	1.2V
A8	B702_L24_P	N23	1.2V	B8	B702_L21_P	N21	1.2V
A9	GND	-	Ground	B9	GND	-	Ground
A10	B702_L22_N	L22	1.2V	B10	B302_L5_N	C12	3.3V
A11	B702_L22_P	K21	1.2V	B11	B302_L5_P	D11	3.3V
A12	GND	-	Ground	B12	GND	-	Ground
A13	B302_L2_N	D14	3.3V	B13	B302_L0_N	E14	3.3V
A14	B302_L2_P	E13	3.3V	B14	B302_L0_P	F14	3.3V
A15	GND	-	Ground	B15	GND	-	Ground
A16	PS_MIO31	AD6	1.8V	B16	PS_MIO35	AC7	1.8V
A17	PS_MIO25	Y4	1.8V	B17	PS_MIO37	AE7	1.8V
A18	GND	-	Ground	B18	GND	-	Ground
A19	PS_MIO26	AA5	1.8V	B19	PS_MIO22	AD4	1.8V
A20	PS_MIO33	AA6	1.8V	B20	PS_MIO19	AH4	1.8V
A21	GND	-	Ground	B21	GND	-	Ground
A22	PS_MIO32	AB6	1.8V	B22	PS_MIO20	AF4	1.8V
A23	PS_MIO27	AB5	1.8V	B23	PS_MIO28	AC5	1.8V
A24	GND	-	Ground	B24	GND	-	Ground
A25	PS_MIO14	AC3	1.8V	B25	PS_MIO23	AC4	1.8V
A26	PS_MIO13	AB3	1.8V	B26	PS_MIO24	AA4	1.8V
A27	GND	-	Ground	B27	GND	-	Ground
A28	LPD_MIO24	Y8	1.8V	B28	LPD_MIO4	Y2	1.8V
A29	LPD_MIO23	Y7	1.8V	B29	LPD_MIO3	Y1	1.8V
A30	GND	-	Ground	B30	GND	-	Ground

A31	LPD_MIO5	W2	1.8V	B31	LPD_MIO18	W5	1.8V
A32	LPD_MIO2	W1	1.8V	B32	LPD_MIO12	W4	1.8V
A33	GND	-	Ground	B33	GND	-	Ground
A34	LPD_MIO7	U2	1.8V	B34	LPD_MIO1	U1	1.8V
A35	LPD_MIO6	V2	1.8V	B35	LPD_MIO13	V4	1.8V
A36	GND	-	Ground	B36	GND	-	Ground
A37	FPGA_TDI	AG10	1.8V	B37	FPGA_TCK	AH10	1.8V
A38	FPGA_TMS	AH9	1.8V	B38	FPGA_TDO	AF8	1.8V
A39	GND	-	Ground	B39	GND	-	Ground
A40	+12V		+12V	B40	+12V		+12V

Table 8: Pin assignment of expansion port U23_AB

- Expansion port U23_CD

The pin assignment of U23B expansion port is shown in Table 9:

U23 pin	Signal Name	FPGA Pin number	Level standard	U23 Pin	Signal Name	FPGA Pin number	Level standard
C1	B702_L13_N	R24	1.2V	D1	B702_L14_N	P24	1.2V
C2	B702_L13_P	T23	1.2V	D2	B702_L14_P	R23	1.2V
C3	GND	-	Ground	D3	GND	-	Ground
C4	B702_L26_N	M25	1.2V	D4	B702_L18_N	U22	1.2V
C5	B702_L26_P	N25	1.2V	D5	B702_L18_P	V21	1.2V
C6	GND	-	Ground	D6	GND	-	Ground
C7	B702_L23_N	J22	1.2V	D7	B702_L19_N	R22	1.2V
C8	B702_L23_P	J21	1.2V	D8	B702_L19_P	T21	1.2V
C9	GND	-	Ground	D9	GND	-	Ground
C10	B702_L15_N	M23	1.2V	D10	B702_L20_N	P22	1.2V
C11	B702_L15_P	M22	1.2V	D11	B702_L20_P	R21	1.2V
C12	GND	-	Ground	D12	GND	-	Ground
C13	B302_L3_N	D12	3.3V	D13	B302_L4_N	E11	3.3V
C14	B302_L3_P	E12	3.3V	D14	B302_L4_P	F11	3.3V
C15	GND	-	Ground	D15	GND	-	Ground
C16	PS_MIO34	AB7	1.8V	D16	B302_L6_N	C10	3.3V
C17	PS_MIO30	AE6	1.8V	D17	B302_L6_P	D10	3.3V
C18	GND	-	Ground	D18	GND	-	Ground
C19	PS_MIO29	AD5	1.8V	D19	PS_MIO15	AE3	1.8V
C20	PS_MIO18	AH3	1.8V	D20	PS_MIO21	AE4	1.8V
C21	GND	-	Ground	D21	GND	-	Ground
C22	PS_MIO17	AG3	1.8V	D22	PS_MIO51	AA10	1.8V
C23	PS_MIO16	AF3	1.8V	D23	PS_MIO50	AB10	1.8V
C24	GND	-	Ground	D24	GND	-	Ground

C25	LPD_MIO22	T6	1.8V	D25	PS_MIO36	AD7	1.8V
C26	LPD_MIO15	T5	1.8V	D26	LPD_MIO20	W6	1.8V
C27	GND	-	Ground	D27	GND	-	Ground
C28	LPD_MIO19	Y6	1.8V	D28	LPD_MIO21	U6	1.8V
C29	LPD_MIO16	U5	1.8V	D29	LPD_MIO25	Y9	1.8V
C30	GND	-	Ground	D30	GND	-	Ground
C31	LPD_MIO11	Y3	1.8V	D31	LPD_MIO8	T3	1.8V
C32	LPD_MIO17	V5	1.8V	D32	LPD_MIO14	T4	1.8V
C33	GND	-	Ground	D33	GND	-	Ground
C34	LPD_MIO10	V3	1.8V	D34	LPD_MIO0	T1	1.8V
C35	VCC_BATT		-	D35	LPD_MIO9	U3	1.8V
C36	GND	-	Ground	D36	GND	-	Ground
C37	PS_MODE0	AG8	3.3V	D37	PS_MODE2	AG6	3.3V
C38	PS_MODE1	AG7	3.3V	D38	PS_MODE3	AG5	3.3V
C39	GND	-	Ground	D39	GND	-	Ground
C40	+12V		+12V	D40	+12V		+12V

Table 9: Pin assignment of expansion port U23_CD

- Expansion port U24_AB

The 160-pin connector U24 is used to extend the ordinary IO of BANK302 and BANK703 of the FPGA, as well as the transceiver. See Table 10 for pin assignment of U24_AB expansion port:

U24 pin	Signal Name	FPGA Pin number	Level standard	U24 Pin	Signal Name	FPGA Pin number	Level standard
A1	GND	-	Ground	B1	GND	-	Ground
A2	104_TX2_N	C4	1.2V	B2	104_TX0_N	E4	1.2V
A3	104_TX2_P	C5	1.2V	B3	104_TX0_P	E5	1.2V
A4	GND	-	Ground	B4	GND	-	Ground
A5	104_TX3_N	B7	1.2V	B5	104_TX1_N	D7	1.2V
A6	104_TX3_P	B8	1.2V	B6	104_TX1_P	D8	1.2V
A7	GND	-	Ground	B7	GND	-	Ground
A8	104_CLK1_N	F6	1.2V	B8	104_CLK0_N	H6	1.2V
A9	104_CLK1_P	F7	1.2V	B9	104_CLK0_P	H7	1.2V
A10	GND	-	Ground	B10	GND	-	Ground
A11	103_TX2_N	J4	1.2V	B11	103_TX3_N	G4	1.2V
A12	103_TX2_P	J5	1.2V	B12	103_TX3_P	G5	1.2V
A13	GND	-	Ground	B13	GND	-	Ground
A14	103_TX0_N	N4	1.2V	B14	103_TX1_N	L4	1.2V
A15	103_TX0_P	N5	1.2V	B15	103_TX1_P	L5	1.2V
A16	GND	-	Ground	B16	GND	-	Ground
A17	GND	-	Ground	B17	GND	-	Ground

A18	B302_L10_N	A14	3.3V	B18	B302_L9_N	A13	3.3V
A19	B302_L10_P	B13	3.3V	B19	B302_L9_P	B12	3.3V
A20	GND	-	Ground	B20	GND	-	Ground
A21	B302_L1_N	C13	3.3V	B21	B703_L20_N	D21	1.5V
A22	B302_L1_P	C14	3.3V	B22	B703_L20_P	D20	1.5V
A23	GND	-	Ground	B23	GND	-	Ground
A24	B703_L21_N	C21	1.5V	B24	B703_L18_N	H22	1.5V
A25	B703_L21_P	B20	1.5V	B25	B703_L18_P	G21	1.5V
A26	GND	-	Ground	B26	GND	-	Ground
A27	B703_L16_N	B23	1.5V	B27	B703_L24_N	F24	1.5V
A28	B703_L16_P	C23	1.5V	B28	B703_L24_P	F23	1.5V
A29	GND	-	Ground	B29	GND	-	Ground
A30	B703_L8_N	E26	1.5V	B30	B703_L26_N	D26	1.5V
A31	B703_L8_P	F26	1.5V	B31	B703_L26_P	D25	1.5V
A32	GND	-	Ground	B32	GND	-	Ground
A33	B703_L1_N	G28	1.5V	B33	B703_L7_N	G26	1.5V
A34	B703_L1_P	H27	1.5V	B34	B703_L7_P	G25	1.5V
A35	GND	-	Ground	B35	GND	-	Ground
A36	B703_L6_N	J26	1.5V	B36	B703_L0_N	H28	1.5V
A37	B703_L6_P	H25	1.5V	B37	B703_L0_P	J27	1.5V
A38	GND	-	Ground	B38	GND	-	Ground
A39	B703_L5_N	B28	1.5V	B39	B703_L12_N	H24	1.5V
A40	B703_L5_P	C27	1.5V	B40	B703_L12_P	H23	1.5V

Table 10: Pin assignment of expansion port U24_AB

- Expansion port U24_CD

Pin assignment of U24_CD expansion port is shown in Table 11:

U24 pin	Signal Name	FPGA Pin number	Level standard	U24 Pin	Signal Name	FPGA Pin number	Level standard
C1	GND	-	Ground	D1	GND	-	Ground
C2	104_RX1_N	D1	1.2V	D2	104_RX0_N	F1	1.2V
C3	104_RX1_P	D2	1.2V	D3	104_RX0_P	F2	1.2V
C4	GND	-	Ground	D4	GND	-	Ground
C5	104_RX3_N	A4	1.2V	D5	104_RX2_N	B1	1.2V
C6	104_RX3_P	A5	1.2V	D6	104_RX2_P	B2	1.2V
C7	GND	-	Ground	D7	GND	-	Ground
C8	103_CLK1_N	K6	1.2V	D8	103_CLK0_N	M6	1.2V
C9	103_CLK1_P	K7	1.2V	D9	103_CLK0_P	M7	1.2V
C10	GND	-	Ground	D10	GND	-	Ground
C11	103_RX2_N	K1	1.2V	D11	103_RX3_N	H1	1.2V

C12	103_RX2_P	K2	1.2V	D12	103_RX3_P	H2	1.2V
C13	GND	-	Ground	D13	GND	-	Ground
C14	103_RX1_N	M1	1.2V	D14	103_RX0_N	P1	1.2V
C15	103_RX1_P	M2	1.2V	D15	103_RX0_P	P2	1.2V
C16	GND	-	Ground	D16	GND	-	Ground
C17	GND	-	Ground	D17	GND	-	Ground
C18	B302_L8_N	A11	3.3V	D18	B302_L7_N	A10	3.3V
C19	B302_L8_P	B11	3.3V	D19	B302_L7_P	B10	3.3V
C20	GND	-	Ground	D20	GND	-	Ground
C21	B703_L19_N	F21	1.5V	D21	B703_L13_N	G23	1.5V
C22	B703_L19_P	E20	1.5V	D22	B703_L13_P	F22	1.5V
C23	GND	-	Ground	D23	GND	-	Ground
C24	B703_L14_N	E23	1.5V	D24	B703_L22_N	A21	1.5V
C25	B703_L14_P	E22	1.5V	D25	B703_L22_P	A20	1.5V
C26	GND	-	Ground	D26	GND	-	Ground
C27	B703_L9_N	B25	1.5V	D27	B703_L23_N	B22	1.5V
C28	B703_L9_P	C25	1.5V	D28	B703_L23_P	C22	1.5V
C29	GND	-	Ground	D29	GND	-	Ground
C30	B703_L25_N	F25	1.5V	D30	B703_L17_N	A24	1.5V
C31	B703_L25_P	E24	1.5V	D31	B703_L17_P	A23	1.5V
C32	GND	-	Ground	D32	GND	-	Ground
C33	B703_L15_N	C24	1.5V	D33	B703_L10_N	A26	1.5V
C34	B703_L15_P	D24	1.5V	D34	B703_L10_P	A25	1.5V
C35	GND	-	Ground	D35	GND	-	Ground
C36	B703_L2_N	F28	1.5V	D36	B703_L11_N	B27	1.5V
C37	B703_L2_P	G27	1.5V	D37	B703_L11_P	B26	1.5V
C38	GND	-	Ground	D38	GND	-	Ground
C39	B703_L4_N	C28	1.5V	D39	B703_L3_N	E28	1.5V
C40	B703_L4_P	D27	1.5V	D40	B703_L3_P	E27	1.5V

Table 11: Pin assignment of expansion port U24_CD

Part 1.10: Structure Diagram

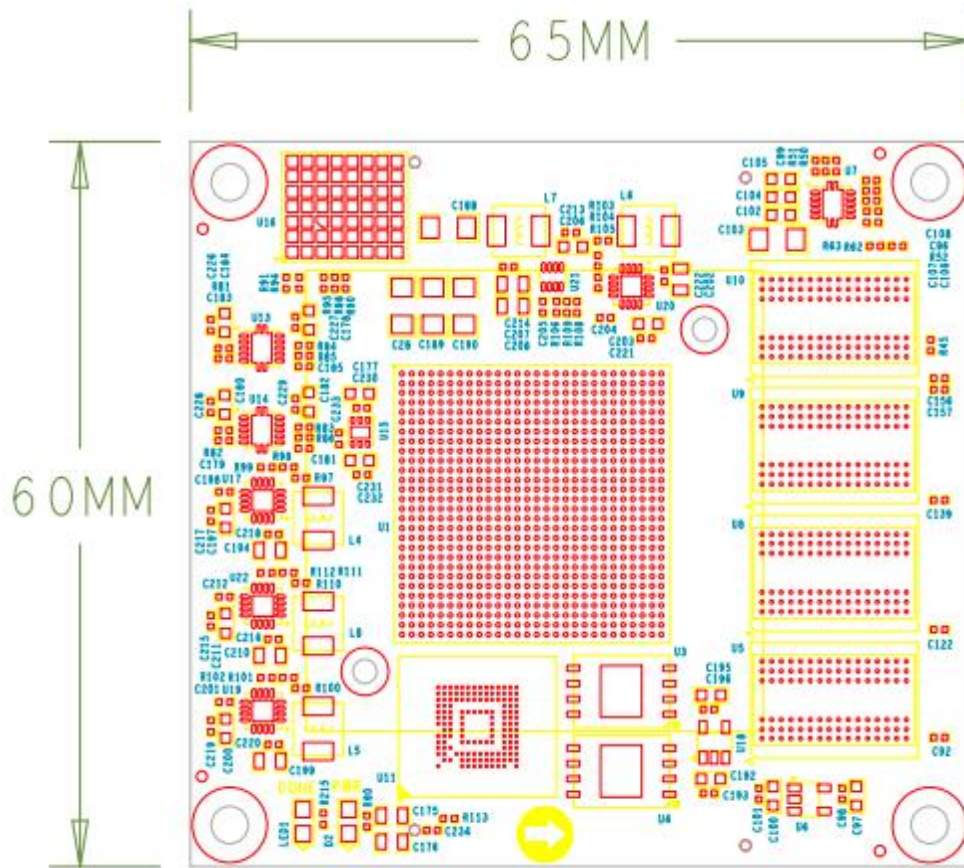

Figure 11: Front View (TOP View)